

# KIT HP HP KIT

KIT COMPLETO PER POMPE DI CALORE  
HEAT PUMP COMPLETE KIT



## SERIE KIT HP



OTTIMIZZATO PER  
POMPE DI CALORE  
OPTIMIZED FOR  
HEAT PUMPS

### CARATTERISTICHE PRINCIPALI

Il KIT HP MUT è una soluzione completa e preconfigurata, progettata specificamente per impianti con pompa di calore e sistemi ibridi, dove affidabilità, protezione e semplicità di installazione sono fattori determinanti. Pensato per rispondere alle esigenze tipiche dei moderni sistemi a bassa temperatura, il kit integra componenti selezionati per garantire corretta gestione del circuito, protezione dell'impianto e continuità di esercizio, anche in condizioni operative critiche.

La presenza delle **Valvole antigelo N-ICE MUT** protegge l'impianto dal rischio di congelamento, mentre il **Defangatore Compact Magnum** assicura un'elevata capacità di separazione delle impurità, contribuendo a preservare nel tempo l'efficienza della pompa di calore e degli altri componenti dell'impianto. Nella versione PLUS, il kit è completato dal **Degasatore DG HP**, ideale per sistemi ad alta efficienza, dove l'eliminazione dell'aria e dell'eventuale gas refrigerante infiammabile, sono fondamentali per garantirne la sicurezza ed efficienza energetica degli impianti idronici.

### MAIN CHARACTERISTICS

The **MUT HP KIT** is a complete, pre-configured solution specifically designed for heat pump systems and hybrid installations, where reliability, protection, and ease of installation are critical factors. Engineered to meet the typical requirements of modern low-temperature systems, the kit integrates carefully selected components to ensure proper circuit management, system protection, and operational continuity, even under demanding operating conditions.

The inclusion of **N-ICE MUT antifreeze valves** protects the system against the risk of freezing, while the **Compact Magnum Dirt Separator** ensures high impurity separation efficiency, helping to preserve the long-term performance of the heat pump and other system components. In the **PLUS** version, the kit is complemented by the **DG HP Air Separator**, ideal for high-efficiency systems where the removal of air and any flammable refrigerant gases is essential to guarantee both safety and energy efficiency in hydronic systems.

## KIT HP BASIC 1" - 1"¼

CODICE	MODELLO	DESCRIZIONE	MIS	CONF.	IMBALLO
7.030.03882	KIT HP BASIC G1"	Kit HP Basic prodotti impianti PDC: 1pz DF COMPACT MAGNUM in linea 1"F + 2pz N-ICE Mut 1"M	1"F + 1"M	1	1
7.030.03883	KIT HP BASIC G1¼	Kit HP Basic prodotti impianti PDC: 1pz DF COMPACT MAGNUM in linea + 2pz N-ICE Mut attacchi maschio	1"¼M	1	1

## KIT HP PLUS 1" - 1"¼

CODICE	MODELLO	DESCRIZIONE	MIS	CONF.	IMBALLO
7.030.03884	KIT HP PLUS G1"	Kit HP Plus prodotti impianti PDC: 1pz DF COMPACT MAGNUM in linea 1"F + 2pz N-ICE Mut 1"M + 1 pz DG HP 25-VS 1"F	1"F + 1"M + 1"F	1	1
7.030.03885	KIT HP PLUS G1¼	Kit HP Plus prodotti impianti PDC: 1pz DF COMPACT MAGNUM in linea + 2pz N-iceMut + 1 pz DG HP 32E-VS - attacchi maschio	1"¼M	1	1



# KIT HP BASIC

## 1" - 1 1/4"

KIT STANDARD PER POMPE DI CALORE CON DEFANGATORE E VALVOLE ANTIGELO  
 STANDARD KIT FOR HEAT PUMPS WITH DIRT SEPARATOR AND ANTIFREEZE VALVES

**2 N-ICEMUT**



**N-ICEMUT**  
 SCHEDA TECNICA  
 TECHNICAL SHEET

**VALVOLE ANTIGELO**  
 ANITFREEZE VALVES

**1 COMPACT MAGNUM**



**COMPACT MAGNUM**  
 SCHEDA TECNICA  
 TECHNICAL SHEET

**DEFANGATORE MAGNETICO**  
 MAGNETIC DIRT SEPARATOR



Kit completo per la protezione di sistemi idronici a pompa di calore e sistemi ibridi

# Kit HP basic

R290 R32

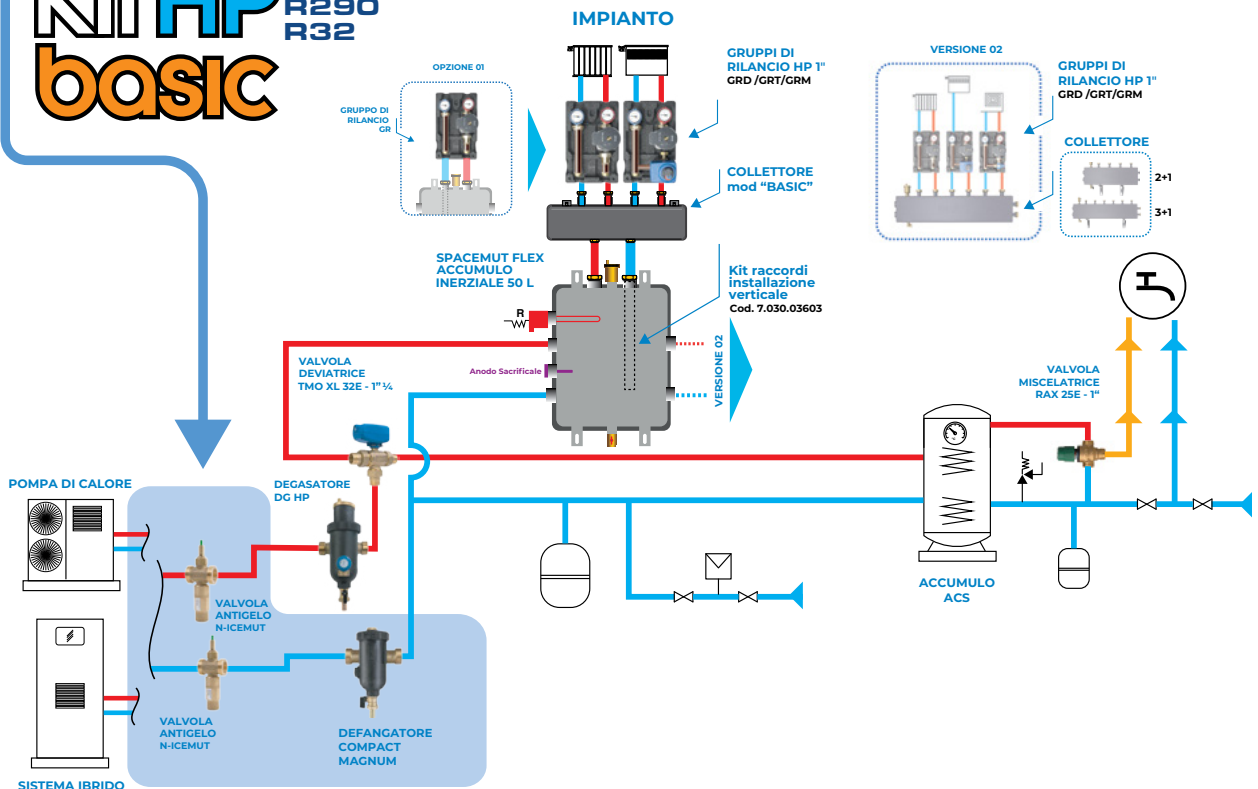



# KIT HP PLUS

## 1" - 1 1/4"

KIT STANDARD PER POMPE DI CALORE CON DEFANGATORE E VALVOLE ANTIGELO  
 STANDARD KIT FOR HEAT PUMPS WITH DIRT SEPARATOR AND ANTIFREEZE VALVES

2 N-ICEMUT



**N-ICEMUT**  
 SCHEDA TECNICA  
 TECHNICAL SHEET

**VALVOLE ANTIGELO**  
 ANITFREEZE VALVES

1 COMPACT MAGNUM



**COMPACT MAGNUM**  
 SCHEDA TECNICA  
 TECHNICAL SHEET

**DEFANGATORE MAGNETICO**  
 MAGNETIC DIRT SEPARATOR

1 DG HP



**DG HP VS**  
 SCHEDA TECNICA  
 TECHNICAL SHEET

**DEGASATORE CON VALVOLA DI SICUREZZA**  
 DEGASSER WITH SAFETY VALVE

HighPower  
**Magnetic**  
 cartridge

8 STAGES  
 CYCLONIC  
 FILTER

8 STAGES  
 CYCLONIC  
 FILTER

Kit completo per la protezione di sistemi idronici a pompa di calore e sistemi ibridi

**KIT HP plus**  
 R290  
 R32

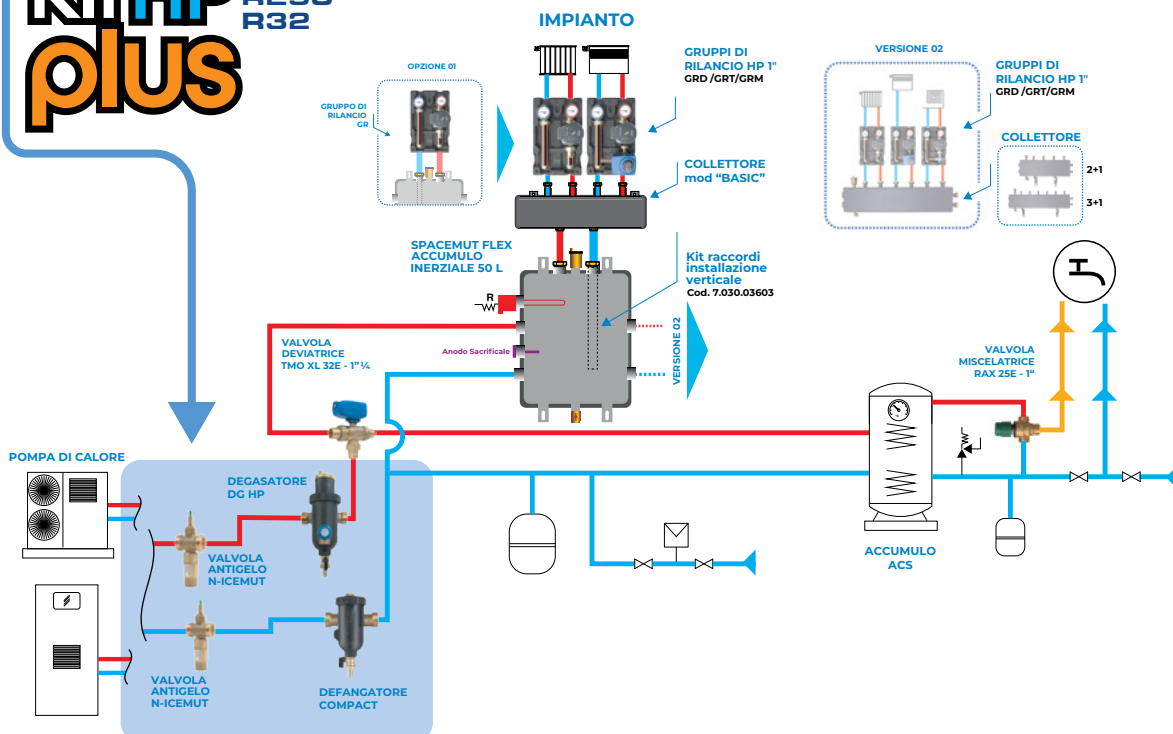



# DATI DIMENSIONALI - DIMENSIONAL SHEET

Dimensioni in [mm]

## N-ICE MUT

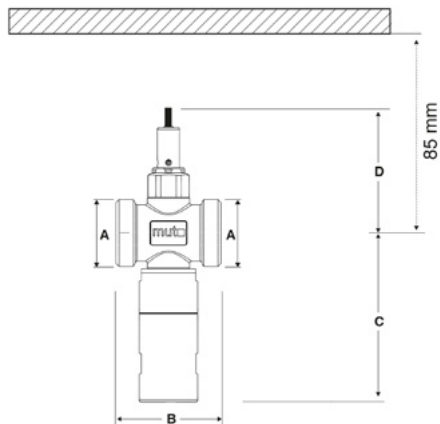

	1"	1 1/4"
CODICE / CODE	<b>7.030.03313</b>	<b>7.030.03314</b>
MODELLO / MODEL	<b>N-ICEMUT 25 MM</b>	<b>N-ICEMUT 32 MM</b>
DN	25	32
A ISO228/1 Filettata maschio Male Threaded	G 1" B	G 1 1/4 B
B [mm]	52	59
C [mm]	84	88
D [mm]	61	65
Kvs	56	71

## COMPACT MAGNUM

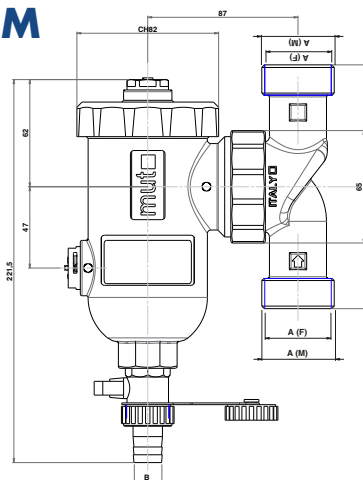

	1"	1 1/4"
CODICE / CODE	<b>7.030.03116</b>	<b>7.030.02990</b>
MODELLO / MODEL	<b>COMPACT MAGNUM LINEA</b>	<b>COMPACT MAGNUM LINEA</b>
A Ø Racc. (ingresso) Ø Conn. (inlet)	1" F	1 1/4" M
A Ø Racc. (uscita) Ø Conn. (outlet)	1" F	1 1/4" M
B Ø Rub. scarico Ø Drain valve	3/4" M	3/4" M
Massa [kg] Mass [kg]	1.45	1.45
Kvs [m3/h]	10	10

## DG HP-VSA

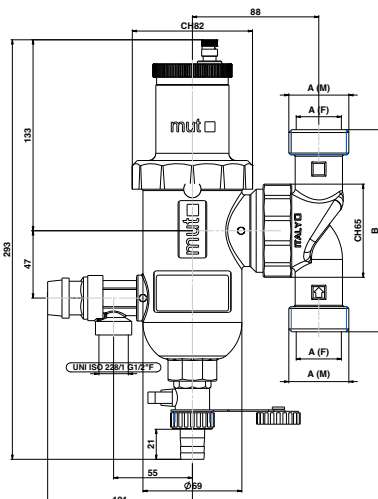

	1"	1 1/4"
CODICE	<b>7.030.03089</b>	<b>7.030.03090</b>
MODELLO / MODEL	<b>MODELLO MODEL</b>	<b>DG HP 32E-VS</b>
A Ø Racc. (ingresso) Ø Conn. (inlet)	1" F	1 1/4" M
A Ø Racc. (uscita) Ø Conn. (outlet)	1" F	1 1/4" M
B [mm]	141	141
Valvola di sicurezza Safety Valve	3 bar - 1/2" F	3 bar - 1/2" F
Ø Rub. scarico Ø Drain valve	3/4" M	3/4" M
Massa [kg] Mass [kg]	1.50	1.55
Kvs	10	10

Ci riserviamo il diritto di apportare miglioramenti e modifiche ai prodotti descritti ed ai relativi dati tecnici in qualsiasi momento e senza preavviso.

We reserve the right to change our products and their relevant technical data, contained in this publication, at any time and without prior notice.



**MUT MECCANICA TOVO S.p.A.**

Via Bivio S. Vitale, 36075 Montecchio Maggiore (VI) - ITALY  
Tel. +39 0444 491744 - Fax +39 0444 490134

[www.mutmeccanica.com](http://www.mutmeccanica.com) - [mut@mutmeccanica.com](mailto:mut@mutmeccanica.com)